

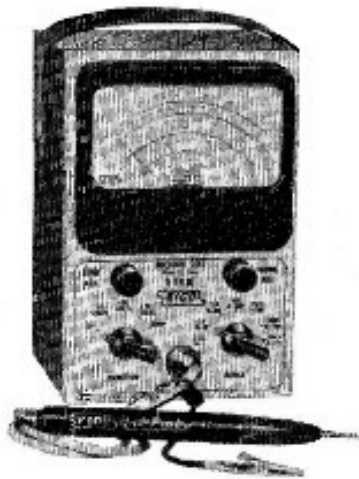

# INSTRUCTION MANUAL

---



## **Model 232** **PEAK to PEAK VTVM**

ELECTRONIC INSTRUMENT CO., Inc. 84 Withers Street, Brooklyn, N. Y.

## general description

Expressly designed for TV servicing, the Model 232 (249) Peak-to-Peak VTVM features a full-wave, high frequency rectifier circuit that responds to and measures the peak-to-peak voltage value of complex and sine waveforms even when DC is present. It also reads the rms voltage of sine waves (on a separate scale), dc voltage values, and resistance values. For consistently high accuracy, there are seven non-skip ranges on all functions to provide a uniform 3 to 1 scale ratio between adjacent ranges.

The input resistance on all dc voltage ranges is 11 megohms, which is high enough to prevent loading error and yet not so high as to impair the stability of the instrument. The dc voltage ranges may be extended to 30,000 volts (with accessory High Voltage Probe HVP-1 or HVP-2) and may also be used for RF voltage measurement up to 250 mc (with accessory RF Probe Model PRF-11). The frequency response of the ac voltage ranges extends from 30 cps to 3 mc. for a source of 100 ohms or less.

Facilities that increase the accuracy, versatility, and ease of operation include zero-center indication for discriminator alignment and bias measurements; zero adjustment unaffected by changing function or range; separate scale for low ac voltage measurement; electronic protection against meter burn out; adjustment of all calibration controls without cabinet removal; and UNI-PROBE, a single unit probe used for all functions.

The Model 232 (4 1/2" meter) and the Model 249 (7 1/2" meter) are identical electrically. Where portability is desired, the Model 232 is preferable because of its extremely compact design. The Model 249 is an ideal bench instrument, having extra long scales to minimize reading errors and permitting permanent placement of the equipment at a practical working distance. Both instruments are ruggedly housed, professional in appearance, and highly dependable and trustworthy measuring devices that will prove extremely valuable in television, fm-am radio servicing, and many industrial applications.

## specifications

### DC VOLTMETER:

Ranges ..... 0 to 1.5, 5, 15, 150, 500, 1500 volts

Input Resistance ..... 11 M $\Omega$

Accuracy .....  $\pm 3\%$  of full scale or better.

Range extended to 30,000 volts with High Voltage Probe HVP-1 or HVP-2 (1090 M $\Omega$  multiplier resistor recommended).

## AC VOLTMETER:

RMS values of Sine Waves . . . . . 0 to 1.5 volts on separate LOW-AC scale  
0 to 5, 15, 50, 150, 500, 1500 volts  
Peak-to-Peak Values of Sine . . . 0 to 4 volts on separate LOW-AC scale  
& Complex Waves . . . . . 0 to 14, 42, 140, 420, 1400, 4200 volts  
Input Resistance & Capacity . . . . 1 M $\Omega$ , shunted by 60 mmf (approx.)  
Accuracy . . . . .  $\pm 5\%$  of full scale or better.  
Frequency Response . . . . . 30 cps to 3 Mc (source Z 100  $\Omega$  or less)  
RF voltage measurement to 250 Mc (accuracy  $\pm 10\%$ ) with RF Probe PRF-11

OHMMETER: 0 to 1000 Megohms in 7 ranges — RX1, RX10, RX100, RX1000  
RX10K, RX100K, RX1Meg (10 ohms center scale on RX1 range)

TUBE COMPLEMENT: 1-6AL5 twin-diode as full-wave peak-to-peak rectifier  
1-12AU7 twin-triode in vacuum-tube balanced bridge circuit

POWER SUPPLY: Transformer-operated selenium rectifier; 1.5 volt flashlight cell.

POWER REQUIREMENTS: 105-125 volts AC, 50-60 cps; drain: 5 watts

OVERALL SIZE: Model 232 - 8 1/2" h, 5" w, 5" d; Model 249 - 8 1/2" h, 13" w, 5" d

WEIGHT: Model 232 - 7 pounds; Model 249 - 9 pounds

CASE: Steel cabinet, grey wrinkle finish; satin-aluminum panel, deep-etched and rub-proof

Supplied complete with UNI-PROBE (combined isolating and direct probe, used for all functions and ranges) and ground lead.

## **operation**

### PRELIMINARY ADJUSTMENTS

1. Connect the UNI-PROBE to the VOLTS-OHMS terminal, and the Ground Cable to the GND. terminal.
2. Plug the line cord into an outlet supplying 105-125 volts AC, 50-60 cps.
3. Set the FUNCTION selector at "+DC VOLTS" and the UNI-PROBE at "DC". Allow several minutes for the instrument to warm up. If necessary, use the ZERO ADJ. control to set the meter pointer within scale limits during

the warm-up period.

4. Short the UNI-PROBE to the Ground Cable and set the meter pointer at the left-hand zero with the ZERO ADJ. control. If turning the FUNCTION selector to "-DC VOLTS" changes the position of the meter pointer, readjust the mechanical zero of the meter as described under MAINTENANCE.

5. Set the FUNCTION selector at "OHMS", the UNI-PROBE at "AC-OHMS", and the RANGE selector at "RX10". Separate the UNI-PROBE from Ground Cable. The meter pointer should move to approximately full scale.

6. Use the OHMS ADJ. control to position the meter pointer on the last graduation of the scale.

7. Set the FUNCTION selector at "AC VOLTS". If the meter pointer does not read zero volts when the RANGE selector is at "1.5 V", refer to the "AC Voltmeter Balance Adjustment" and "AC Voltmeter Calibration" sections under Maintenance.

Note: Although the meter is protected against burn-out under ordinary overloads, repeated overloads may impair the accuracy of the movement. For this reason, in the following instructions the operator is advised to first make a trial measurement at a range setting higher than the voltage expected.

### DC VOLTAGE MEASUREMENT

1. Set the UNI-PROBE at DC and the FUNCTION selector at either "+DC VOLTS" or "-DC VOLTS", depending upon the polarity of the voltage to be measured with respect to ground.

2. Set the RANGE selector at a position considerably higher than the voltage to be measured.

3. Connect the Ground Cable to the ground side of the voltage being measured and touch the UNI-PROBE to the high side.

4. Reset the RANGE selector to the position which gives a reading nearest to full scale and read the dc voltage on the meter.

### ZERO CENTER INDICATION

Zero-center indication permits observation of either positive or negative voltage excursions without resetting of the function selector. To prepare the instrument for zero-center indication, simply set the FUNCTION selector at "+DC VOLTS" and turn the ZERO ADJ. control (with no voltage applied) un-

til the meter pointer is set at the center "-0+". The range selector should be set first to a position at least twice the voltage to be measured and then to the lowest position which permits the meter pointer to remain on the scale. The value of a positive voltage (deflection to the right of the center "-0+") is obtained by subtracting half the range selector setting from the dc voltage reading on the scale. The value of a negative voltage (deflection to the left of the center "-0+") is obtained by subtracting the dc voltage reading on the scale from half the range selector setting.

### RESISTANCE MEASUREMENT

Remove all power from the equipment under test before making resistance measurements so that no voltages are present.

1. Set the UNI-PROBE at "AC-OHMS" and the FUNCTION selector at "OHMS".
2. Set the RANGE selector at "RX10".
3. Short the UNI-PROBE to the Ground Cable. The meter pointer should be at the left-hand zero. Use the ZERO ADJ. control to reset the pointer at the left-hand "0", if necessary.
4. Separate the UNI-PROBE from the Ground Cable. The meter pointer should be at the last line on the "OHMS" scale. Use the OHMS ADJ. control to reset the pointer at the last line on the "OHMS" scale, if necessary.
5. Connect the clip on the Ground Cable to one terminal of the resistance to be measured and touch the UNI-PROBE to the other terminal.
6. Reset the RANGE selector to give a convenient deflection and multiply the reading on the "OHMS" scale by the factor indicated at the RANGE selector setting.

Caution: Meter movements, thermocouples and other low-current, low-resistance devices may be damaged unless a range above "RX10" is used. At the "RX1" and "RX10" positions, the instrument applies up to 1.5 volts to the resistance under measurement.

### RESISTANCE MEASUREMENT ABOVE 1000 MEGOHMS

The upper limit of direct resistance measurement with this instrument is 1000 megohms. The leakage resistance of small paper and mica capacitors usually exceeds the value. To measure resistance values above 1000 megohms, an external dc voltage source between 20 and 500 volts can be used to

obtain a measurable pointer deflection. The circuit connections are shown in Fig. 2 and the procedure is as follows.

1. Set the FUNCTION selector at "+ DC VOLTS" and the UNI-PROBE at "DC".
2. Measure the voltage at point A and then the voltage at point B.
3. Compute the resistance from the following formula.

$$R_x \text{ (megohms)} = \frac{11 [(Volts \text{ at "A"}) - (Volts \text{ at "B"})]}{(Volts \text{ at "B"})}$$

Example: In measuring a resistance by the method of Fig. 2, the external dc voltage supply is 300 volts. The instrument measures 300 volts at point A and 1.1 volts at B. Then,

$$R_x = \frac{11 (300 - 1.1)}{1.1} = 3000 \text{ megohms (approx.)}$$

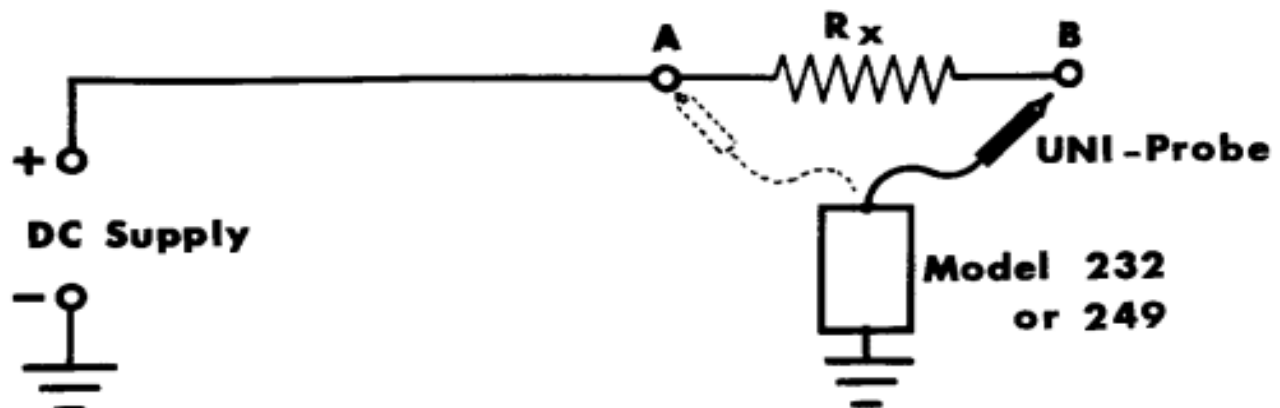

**Fig. 2**

### AC VOLTAGE MEASUREMENTS

1. Set the UNI-PROBE at "AC-OHMS" and the FUNCTION selector at "AC VOLTS".
2. If necessary, use the ZERO ADJ. control to set the meter pointer at the left-hand "0".
3. Set the RANGE selector at a position considerably higher than the voltage to be measured.
4. Connect the Ground Cable to the ground side of the voltage source to be measured and touch the UNI-PROBE to the high side.

5. Reset the RANGE selector to the position which gives a reading nearest to full scale and read the ac voltage.

NOTE: All RMS scales are in black with full-scale values of 1.5, 5, 15, 50, 500, and 1500 volts. All peak-to-peak scales are in red with full-scale values 4, 14, 42, 140, 420, 1400, and 4200 volts. When the instrument is set at the 1.5 volt range, the RMS or P-P scales on the lowest arc (designated as LOW-AC) are read; on higher ranges, the scales on the two center arcs are read. It should be noted that the fixed ratio of 2.83 to 1 between corresponding peak-to-peak and rms scales is derived from the relationship between the peak-to-peak and rms values of a sine wave. Therefore, while peak-to-peak readings are valid regardless of whether the waveform is complex or sine, rms readings are valid only for sine waves. Note also that the time delay between the instant the leads are removed from the source being measured and the instant the meter pointer returns to zero is normal and is the result of circuit constants selected to permit accurate measurement of recurrent pulses with low repetition rates.

## **applications**

This instrument may be used to maintain and service television receivers, fm-am and communication receivers, transmitters, audio equipment, and pulsed electronic and electro-mechanical equipment. Indicative of its versatility are some of the special applications described below.

OSCILLATOR GRID-BIAS MEASUREMENT: The negative dc voltage developed on the oscillator grid is always directly proportional to the strength of oscillation. This voltage can be measured very readily at the oscillator grid while the band switch is turned to the various bands, and in each of its positions the main tuning condenser is rotated from minimum capacity. This will give an indication of the strength of oscillation at all frequencies within the oscillator's range.

AVC-VOLTAGE MEASUREMENTS: The automatic volume control voltage developed by the incoming signal can be measured at a number of places in the receiver. This negative voltage first appears across the diode load resistor. It may also be measured along the avc bus and at the grids of the rf tubes being controlled. The dc voltage measured at the diode load resistor is a very convenient output indication during receiver alignment.

Owing to the high input resistance of this instrument, it is possible to measure bias (avc) voltage on the grid of rf and if amplifier tubes without disrupting the signal.

DC SUPPLY VOLTAGE MEASUREMENTS: Power supply dc voltages can be



measured at the rectifier filaments and in the filter circuits. Plate, screen, and cathode dc voltages can be measured at the corresponding pins of the tube sockets.

**BIAS CELL VOLTAGE MEASUREMENTS:** This instrument will accurately measure the voltage of a bias cell. Current drawing voltmeters are not capable of making this measurement and in many cases will damage the cell.

**DETECTION OF GASSY TUBES:** One effect of a gassy tube is to reduce the normal negative grid bias, or even make the grid positive. This instrument is ideal for measuring the voltage directly at the control grid of any tube in order to determine whether or not this effect is present. Excessive gas will cause the tube to cease operating normally, and in an audio amplifier will usually cause the volume control to become noisy. This amount of gas will not always produce a noticeable change in the operation of the radio receiver. Consequently if repeated difficulty is experienced with volume controls becoming noisy in this type of circuit, this instrument should be used to check for incorrect bias.

**OUTPUT INDICATION:** To measure output in the alignment of am and TV receivers, the instrument is prepared for dc voltage measurement and usually connected to the load resistor of the second detector while the circuit components are adjusted for optimum output. In an fm receiver, the instrument is connected across the limiter load resistor. The zero-center feature is very useful for the alignment of fm discriminators.

**DB MEASUREMENTS:** In order to avoid crowding of frequently used scales, there is no db scale on the meter. Another reason for the absence of this scale is that there are many different reference levels in use and each reference level results in a different scale. Fig. 1 is a graph for one accepted reference level, namely 0.775 volts across 600 ohms resistive load (1 milliwatt), with which rms ac voltage readings can be converted to db readings. However, the db value read from the chart is correct only when the voltage reading has been taken across a 600 ohm resistive load. If the reading has not been taken across a 600 ohm load, the db value read from the chart must be corrected by adding algebraically to it the correction increment specified in the chart of Fig. 3 for the particular resistive load. If the resistive load is not included in the chart, the correction increment may be calculated from the following formula.

$$\text{Correction Increment} = 10 \log \frac{600}{R} \text{ (where R is the resistive load)}$$

It should be noted that decibel measurements must be made with a sine wave form to avoid waveform error and that the correlation between decibels and ear response is greatest at 1000 cycles.



| Load Res. | DB Added |
|-----------|----------|
| 600       | 0        |
| 500       | +0.8     |
| 300       | +3.0     |
| 250       | +3.8     |

| Load Res. | DB Added |
|-----------|----------|
| 150       | +6.0     |
| 50        | +10.8    |
| 15        | +16.0    |
| 8         | +18.8    |
| 3.2       | +22.7    |

**Fig.3**

## operating instructions

The central circuit in the operation of this instrument is a vacuum-tube bridge circuit using a 12AU7 twin-triode. When the bridge is balanced, the voltages at the two cathodes will be equal and the meter connected across them will read zero.

**DC VOLTMETER OPERATION:** When a positive dc voltage is applied, a fraction (depending on the range setting) is taken from the range voltage divider (R12-R18) and applied to the grid of V1a. This causes the current through V1a to increase and consequently, the cathode voltage of V1a to increase. Concurrently the voltage on the arm of R22 tends to increase, which since it tends to make the cathode of V1b more positive, causes a decrease in the plate current and hence in the cathode voltage of V1b. This push-pull action permits a large value of cathode resistance with negligible degeneration and, consequently, greatly increased stability of operation. The meter circuit is connected across the two cathodes and the difference in potential across the meter causes current to flow through the meter from the cathode of V1a to the cathode of V1b.

**AC VOLTAGE MEASUREMENTS:** The applied voltage is first rectified by the twin-diode V2, which serves as a full-wave peak-to-peak rectifier. The operation of this circuit is as follows: On the positive swing of the ac signal, diode V2a conducts and a negative dc voltage equal to the positive peak value builds up on the plate-connected side of C2. As the ac signal voltage swings negative, diode V2a ceases to conduct (and so prevents any discharge of C2) while diode V2b begins to conduct. The negative dc voltage on C2 is added in series to the signal voltage on the negative swing and is applied to the cathode of V2b. As a result, a negative dc voltage equal to the sum of the positive and negative peaks of the positive and negative peaks of the ac signal voltage is built up on the plate-connected side of C3 through conduction of diode V2b and is maintained because of the relatively long time constants of the circuit. To offset the contact potential within V1, an exactly adjusted positive voltage is taken from the junction of R26 and R27 and applied to the V1 rectifier circuit through isolating resistor R28. The peak-to-peak voltage across C3 is attenuated by R29 before application to the range voltage divider and thereafter the operation is similar to dc voltage measurement.

OHMMETER OPERATION: The applied resistance determines the current through the battery and the section of the ohms range network (R5-R11) selected by the range switch. With nothing connected across the input terminals, no current is drawn, and consequently there is no voltage drop across the ohms network. As a result, the entire battery voltage is applied to the grid of V1-a. Potentiometer R30 in the meter circuit is adjusted to produce full-scale deflection (infinity reading) in this condition. A short across the input terminals produces a voltage drop in the ohms range network equal and opposite to the battery voltage and effectively places the grid of V1a at ground potential for a zero reading. Intermediate values of resistance produce voltage drops exceeded by the battery voltage and the difference in voltage is applied to the grid of V1a. This voltage causes an intermediate deflection on the meter which has an ohms scale calibrated to read the applied resistance.

## **maintenance**

Included in this section are instructions for calibration, adjustment, repair, and part replacement.

### CALIBRATION

General: Instruments purchased in kit form must be calibrated before use as described below. Factory-wired instruments have been calibrated and tested at the factory. If a change occurs in the accuracy of the instrument after a long period of use, it is probably due to aging of the components. The accuracy of the instrument may readily be restored by repeating this calibration procedure. Recalibration will also be necessary, whenever parts (tubes, etc.) are replaced.

Mechanical Zero: The meter pointer should rest directly over the left-hand zero when the power is shut off. If the meter pointer comes to rest at a deflected position, adjust it to zero by turning the slotted screw directly beneath the meter face.

Warm-up: Insert the leads and plug the line cord into an outlet supplying 105-125 volts AC, 50-60 cps. Turn the unit on and allow a minimum of 2 hours for the warm-up preliminary to calibration. For maximum stability of calibration, a 36 hour warm-up period is desirable. If necessary, use the ZERO ADJ. control to set the meter pointer within scale limits during the warm-up period.

AC Voltmeter Balance Adjustment: Set the FUNCTION selector at "AC VOLTS", the RANGE selector at "1500 V", and the UNI-PROBE at "AC-

OHMS". Short the UNI-PROBE to the Ground Cable and use the ZERO ADJ. control to set the meter pointer exactly at the left-hand zero. Keeping the leads shorted, reset the RANGE selector at "1.5 V" and use the AC Balance potentiometer, R27, to reset the meter pointer at the left-hand zero.

AC Voltmeter Calibration: Set the FUNCTION selector at "AC VOLTS", the RANGE selector at "150 V", and the UNI-PROBE at "AC-OHMS". Connect the UNI-PROBE and the Ground Cable across the 117 volts AC supply. Adjust the AC Calibration potentiometer, R32, until the meter reads 117 rms volts. If the maximum accuracy of which the instrument is capable is desired ( $\pm 5\%$  of full scale), apply exactly 150 volts (60 cps) on the "150 V" range (or 50 volts on the "50 V" range) and adjust R32 for exactly full-scale deflection.

DC Voltmeter Calibration: Set the FUNCTION selector at "+ DC VOLTS", the RANGE selector at "5 V", and the UNI-PROBE at "DC". Connect the UNI-PROBE and the Ground Cable across two flashlight cells in series, which will provide a voltage of 3.10 volts when fresh. Adjust the DC Calibration potentiometer, R31, until a 3.10 volt reading is obtained on the meter.

Ohmmeter Calibration: No separate calibration is required.

NOTE: Access to the three calibration controls is obtained by temporary removal of the plug-buttons inserted in the side of the cabinet. Fig. 4 shows the location of each control in Models 232 and 249.



Fig.4

## TUBE REPLACEMENT

When a new tube is installed in the instrument, it may be necessary to re-zero when switching from the lowest to the highest dc-voltage ranges unless the tube is aged by operating it in the instrument for 36 hours. The calibration should be checked after this period.

## BATTERY REPLACEMENT

Do not permit an exhausted battery to remain inside the instrument case as the chemicals from a deteriorated battery may damage the components. Indications of a weak battery will be found in the trouble-shooting section.

## TROUBLE-SHOOTING THE MODEL 232 or 249

As an aid to localizing the cause of faulty operation, the following general trouble-shooting procedure has been prepared. Obviously all possible troubles can not be listed and the technician should use the schematic diagram to trace down unlisted troubles. In general, newly constructed kit instruments should be given a through, step-by-step check of the wiring, following the tables and pictorial diagrams in the construction book, in case the trouble is not listed or cannot be corrected by checking the listed possible causes.

### Instrument fails to operate on all functions; tubes do not light

1. Line cord broken or not making contact at outlet.
2. Switch section S1D defective.
3. T1 defective: Check for shorted or open windings.

### Tubes light; ZERO ADJ. does not work properly; meter pointer does not move or bangs to right or left.

1. Incorrect operating voltages on bridge tube V1.
  - a. No B plus or B minus voltage present: Check CR1, C5, T1 high voltage winding, R26, R27, and R24 with ohmmeter; check connections between these components also.
  - b. B plus and B minus voltage present: Open or short in V1 circuit.
  - c. V1 defective: See "Tube Replacement".
2. Switch section S1-C defective or wired incorrectly.
3. Defective meter movement.
4. ZERO ADJ. control erratic in operation: Potentiometer R22 is defective; replace with new control. NOTE: First make sure mechanical zero of pointer is correct. See "Mechanical Zero" under Calibration.

### Meter pointer sticks

1. Cracked or broken jewel bearing in meter. NOTE: Individual replacement parts for meter movement are not available. Meter should be returned for repairs or replaced with new meter.

Intermittent operation on all functions

1. Loose or bad connections in probe or cables.
2. Wiper contact on S1B or S1C defective.
3. Loose or bad connection in bridge circuit wiring, including meter terminals. With power applied, probe wiring and components with insulated probe.
4. V1 defective. Replace as described under "Tube Replacement."
5. CR1 intermittent.

Instrument fails to operate on OHMS; works normally on ac and dc voltage measurements.

1. Battery exhausted or not making contact.
2. Defective wiper contact on switch section S2C.
3. "OHMS" contact (terminal 7) on S1B defective.
4. Open circuit in resistor network or burned out resistor around switch section S2C. Check continuity of network R5 through R11. NOTE: This network is made up of resistors which are added in series as switch is rotated. Therefore, one faulty resistor may cause improper operation on one or more ranges.
5. Loose or broken "Ohms" contact on switch section S1C (terminal 1)

OHMS ADJ. fails to give infinity setting on "OHMS" scale.

1. Battery exhausted.
2. OHMS ADJ. potentiometer, R30 defective.
3. V1 defective. See "Tube Replacement".

Resistance readings inaccurate on some or all "ohms" ranges.

1. One or more resistors in network around switch section S2C have changed value.
2. Excessive leakage in "ohms" circuit. Check switch wafers on S2C and S1B for dirt or damage. NOTE: High humidity may cause leakage and inaccurate readings on high ohms scales. Bake out inside of instrument with light bulb.
3. Shorted wiring in resistor network around S2C.
4. Faulty or high-resistance connections in "ohms" circuit.

Instrument fails to operate on any ac voltage range; works normally on OHMS and DC VOLTS.

1. V2 defective. See "Tube Replacement."
2. AC volts contact on S1A, S1B, S1C, or S2B defective.
3. Faulty wiper contact on S2D.
4. Open or short in circuitry associated with V2. Check out wiring and components values with ohmmeter.
5. C1, C2, or R29 open; C3 shorted.

Meter pointer moves off zero when ranges are changed.

1. "AC Balance" potentiometer R27 out of adjustment. Readjust as describe under "AC Voltmeter Balance Adjustment." If adjustment cannot be made, then
2. R28 or R27 is defective. Check value with ohmmeter.

AC voltage readings inaccurate on some or all ac ranges; performance on ohms and dc voltage ranges is normal.

1. Defective contacts or wipers, or excessive leakage in S2B. Check for loose or dirty contacts.
2. V2 defective. Install new 6AL5. See "Tube Replacement."
3. C2 or C3 leaky.
4. R29 changed in value. Check with ohmmeter.

If instrument is inaccurate on 500 and 1500 volt ranges only, check contacts 10 and 11 on S2D and also R2, R3, and R4. If inaccurate on 1.5 volt range only, replace V2. See "Tube Replacement."

Instrument fails to operate on any range of "+VOLTS" or "-VOLTS"; works normally on ohms and ac volts.

1. UNI-PROBE resistor is open. Try applying low dc-voltage with UNI-PROBE set at "AC-OHMS". If reading is obtained (about 10% high), replace UNI-PROBE resistor.
2. DC voltage contacts on switch sections S2A, S1B, or S1C are defective. Check for loose or broken contacts.

Voltage readings inaccurate on "+VOLTS". "-VOLTS", ac voltage and resistance readings are correct.

1. R31 out of adjustment. Reset as described under "DC Voltmeter Calibration."
2. UNI-PROBE switch is shorted, resulting in readings about 10% high on all +DC and -DC voltage ranges. Use ohmmeter to check for short between input and output of probe at "DC" position as well as "AC-OHMS" position.
3. Resistances in network around S2A has changed value. Check with ohmmeter and replace defective resistors.

#### EICO Repair Service

If your instrument fails to function properly and the cause of the trouble can not be found with the trouble shooting information provided, you may return it to the EICO repair department where it will be repaired at a charge of \$5.00 plus the cost of parts. If your instrument has been built from the kit form, refer to the complete statement of the EICO servicing policy in your construction book. (Note: Please include UNI-PROBE when returning instrument for repair.)



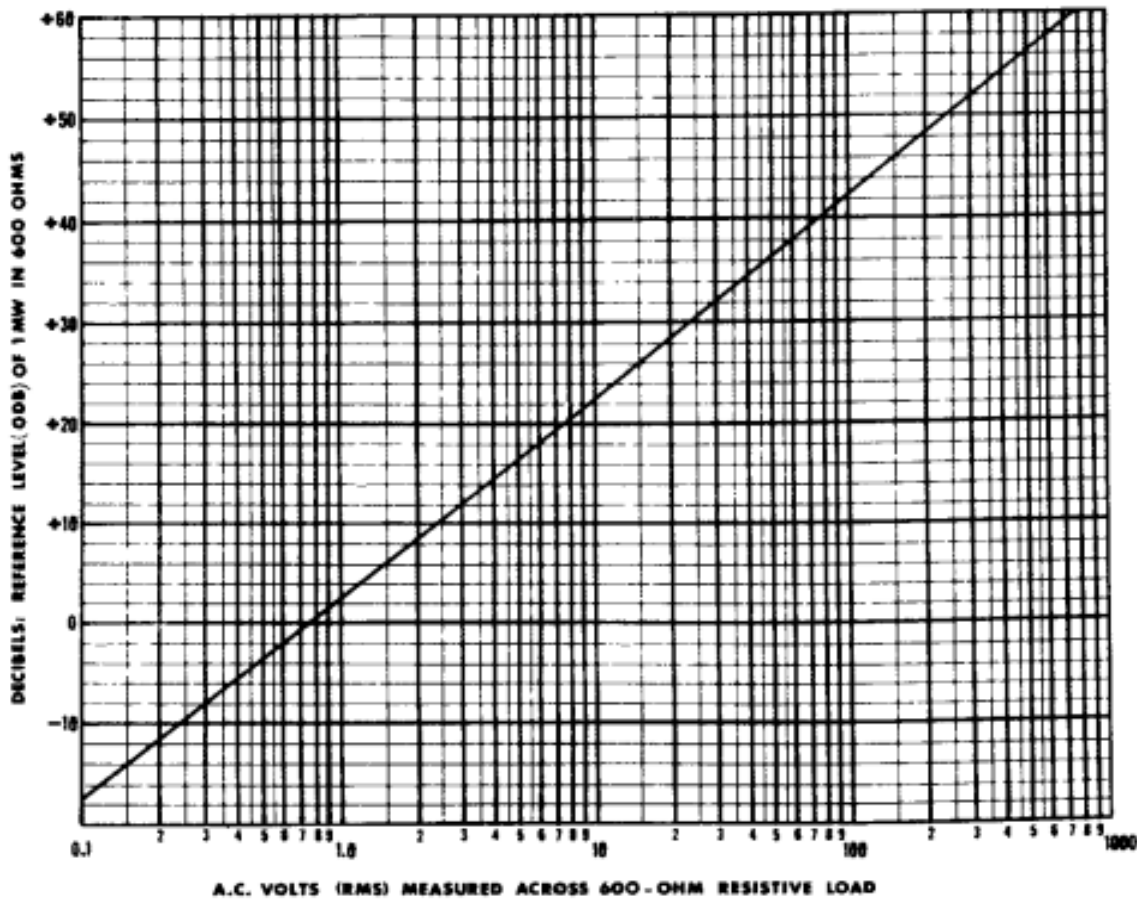

**Fig.1**

**REPLACEMENT PARTS LIST**

| STK.NO. | SYM.   | DESCRIPTION             | STK.NO. | SYM.   | DESCRIPTION              |
|---------|--------|-------------------------|---------|--------|--------------------------|
| 10033   | R19    | Res., 3.3 MΩ, 1/2W, 20% | 11049   | R16    | " 70 KΩ, 1/2W, 1%        |
| 10034   | R25    | " 4.7 MΩ, 1/2W, 20%     | 11050   | R17    | " 20 KΩ, 1/2W, 1%        |
| 10404   | R28    | " 82 MΩ, 1/2W, 10%      | 11051   | R18    | " 10 KΩ, 1/2W, 1%        |
| 10406   | R20,21 | " 680 Ω, 1/2W, 10%      | 11052   | R3     | " 325 KΩ, 1/2W, 1%       |
| 10407   | R1     | " 1 MΩ, 1/2W, 10%       | 11700   | R4     | " 900 KΩ 1W, 1%          |
| 10503   | R26    | " 33K, 1/2W, 5%         | 11701   | R12    | " 7 MΩ, 1W, 1%           |
| 10520   | R24    | " 68K, 1/2W, 5%         | 16000   | R22,30 | " pot., 2 KΩ, linear     |
| 10521   | R23    | " 47K, 1/2W, 5%         | 18014   | R31,32 | " pot., 2 KΩ, linear     |
| 10524   | R29    | " 18 MΩ, 1/2W, 5%       | 18015   | R27    | " pot., 10KΩ, linear     |
| 11025   | R2     | " 150KΩ, 1/2W, 1%       | 20003   | C1     | " cap., .1 mf - 1000V    |
| 11026   | R15    | " 200 K, 1/2W, 1%       | 20007   | C4     | " cap., .003 mf - 400V   |
| 11037   | R9     | " 900 Ω, 1/2W, 1%       | 20012   | C2, C3 | " cap., .025 mf - 400V   |
| 11038   | R8     | " 9 KΩ, 1/2W, 1%        | 23010   | C5     | " cap., elec. 10mf, 150V |
| 11039   | R7     | " 90 KΩ, 1/2W, 1%       | 56000   | BT1    | " battery, 1 1/2 V       |
| 11043   | R11    | " 9.7 Ω, 1/2W, 1%       | 60024   | S2     | " switch, range          |
| 11044   | R10    | " 90 Ω, 1/2W, 1%        | 60025   | S1     | " switch, function       |
| 11045   | R6     | " 900 KΩ, 1/2W, 1%      | 72004   | M1     | " meter, 400 ua          |
| 11046   | R5     | " 9 MΩ, 1/2W, 1%        | 90013   | V1     | " tube, 12AU7            |
| 11047   | R13    | " 2 MΩ, 1/2W, 1%        | 90017   | V2     | " tube, 6AL5             |
| 11048   | R14    | " 700 KΩ, 1/2W, 1%      | 92000   | I1*    | " bulb, #47              |
|         |        |                         | 93003   | CR1    | " rect., 35 ua           |

\*Model 249 only



All switch wafers shown as they appear looking from the front (dark end) of the switch toward the rear. The rear side of each wafer is seen looking END the wafer from the front.

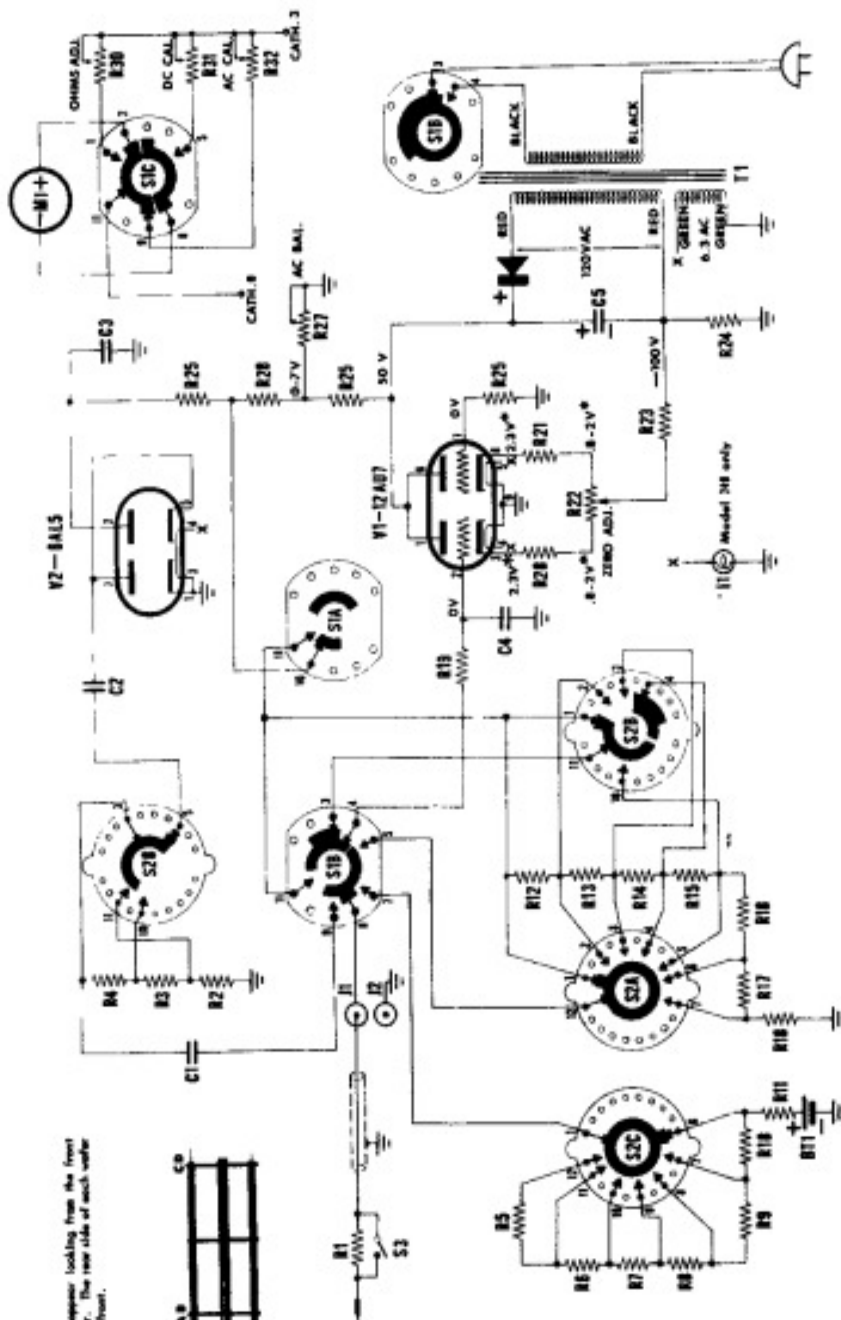

Rotors on all switch wafers shown in extreme counter-clockwise position.

| Sym.   | Description                    | Sym. | Description                    | Sym. | Description                 |
|--------|--------------------------------|------|--------------------------------|------|-----------------------------|
| B1     | battery, 1 1/2 V               | R14  | 700K $\Omega$ , 1/2W, 1%       | R25  | res., 4.7M $\Omega$ , 1/2W  |
| C1     | cap., 1mf - 1000V              | R15  | res., 200K $\Omega$ , 1/2W, 1% | R26  | res., 30K $\Omega$ , 1/2W   |
| C2, C3 | cap., .005mf - 400V            | R16  | res., 70K $\Omega$ , 1/2W, 1%  | R27  | pot., 10K $\Omega$ , linear |
| C4     | cap., .003mf - 400V            | R17  | res., 20K $\Omega$ , 1/2W, 1%  | R28  | res., 60M $\Omega$ , 1/2W   |
| C5     | cap., elec. 10mf - 150V        | R18  | res., 10K $\Omega$ , 1/2W, 1%  | R29  | res., 18M $\Omega$ , 1/2W   |
| CF1    | rect., 35 ma                   | R19  | res., 3.3M $\Omega$ , 1/2W     | S1   | switch, function            |
| CF2    | bulb, 47                       | R20  | res., 680 $\Omega$ , 1/2W      | S2   | switch, range               |
| M1     | meter, 400 $\mu$ a             | R21  | res., 9.7 $\Omega$ , 1/2W      | V1   | tube, 12AU6                 |
| R1     | res., 1M $\Omega$ , 1/2W       | R22  | pot., 2K $\Omega$ , linear     | V2   | tube, 6AL5                  |
| R2     | res., 150K $\Omega$ , 1/2W, 1% | R23  | res., 47K $\Omega$ , 1/2W      |      |                             |
| R3     | res., 325K $\Omega$ , 1/2W, 1% | R24  | res., 68K $\Omega$ , 1/2W      |      |                             |

| FUNCTION SWITCH S1 | Position | Setting   |
|--------------------|----------|-----------|
|                    | 1        | OFF       |
|                    | 2        | AC VOLTS  |
|                    | 3        | -DC VOLTS |
|                    | 4        | +DC VOLTS |
|                    | 5        | OHMS      |

| RANGE SWITCH S2 | Position | Setting        |
|-----------------|----------|----------------|
|                 | 1        | 1.5V, R X 1    |
|                 | 2        | 5V, R X 10     |
|                 | 3        | 15V, R X 100   |
|                 | 4        | 50V, R X 1000  |
|                 | 5        | 150V, R X 10K  |
|                 | 6        | 500V, R X 100K |
|                 | 7        | 1500V, R X 1M  |

\* Model 249 only

# MODEL 232 PEAK TO PEAK VTVM



ELECTRONIC INSTRUMENT CO., INC.  
84 Wilkes St., Brooklyns 11, N. Y.